



Skypod™

Pitched PVC-U skylights

Installation guide

ISSUE 1



All together better

Skypod™ pitched PVC-U skylights

Installation guide



Contents

1. Surveying	3
2. Installation	4
3. Additional information	10

Good surveying is essential to ensure a trouble free successful installation and to avoid costly remakes caused by incorrect measuring.

When surveying it is the surveyor's responsibility to determine that the structural openings and surrounding areas are in a state of good repair and provide the correct dimensions for manufacture.

If in doubt

If in doubt at any stage, please contact the Eurocell branch from which you purchased this product. For branch details please contact **0800 988 3047**.

1. Surveying

Before unpacking the Skypod roof, review the supplied layout drawing (shown in figure 1). The layout will be located in the ancillary box.

Ensure the dimensions of your host building are correct to the supplied. Skypod dimensions shown on the plan are the external face of the supporting upstand.

The Skypod ring beam allows a 10mm tolerance per face if the overall width and length of the upstand perimeter are oversized.

The upstand corners should also be square. Check the difference between the diagonals to see if the ring beam overhang will need adjusting around the perimeter.

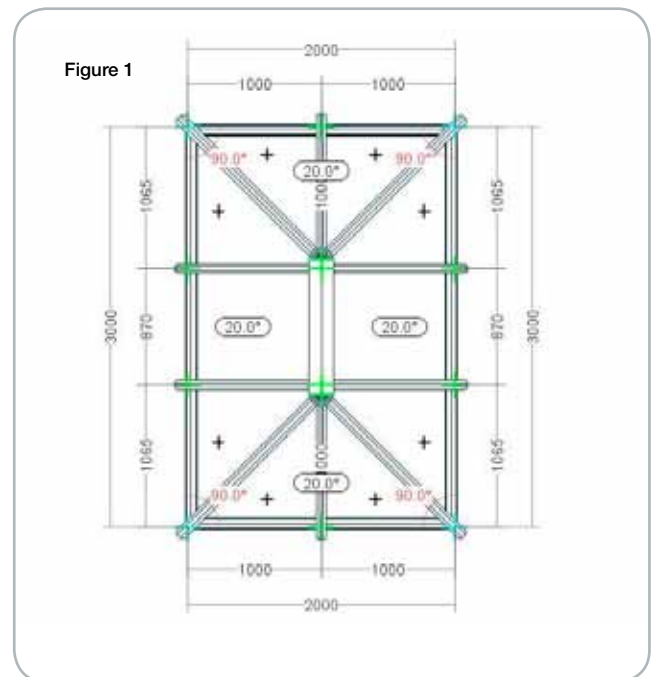

Typical upstand (kerb) detail

Check diagonals to ensure the kerb is square (see figure 2).

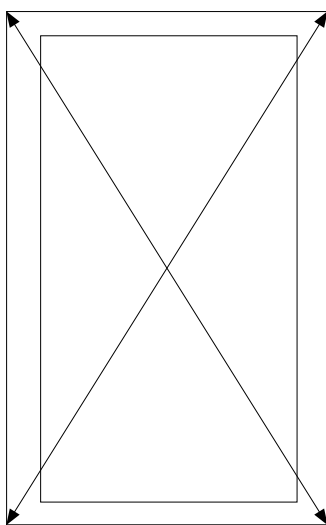
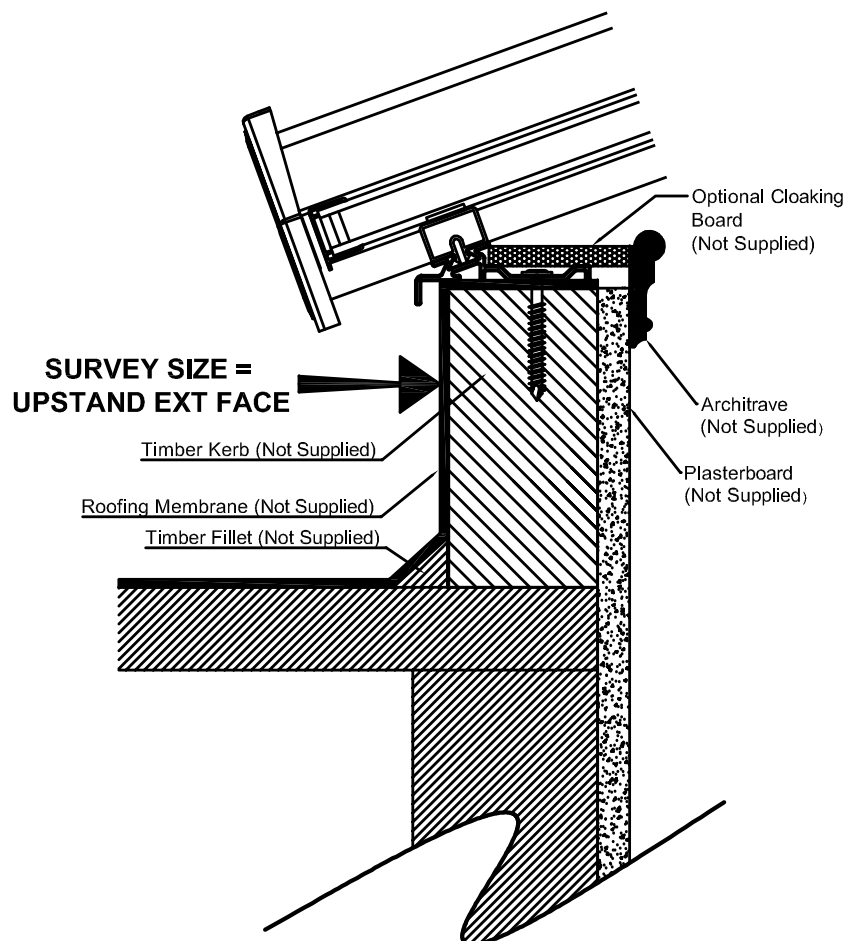
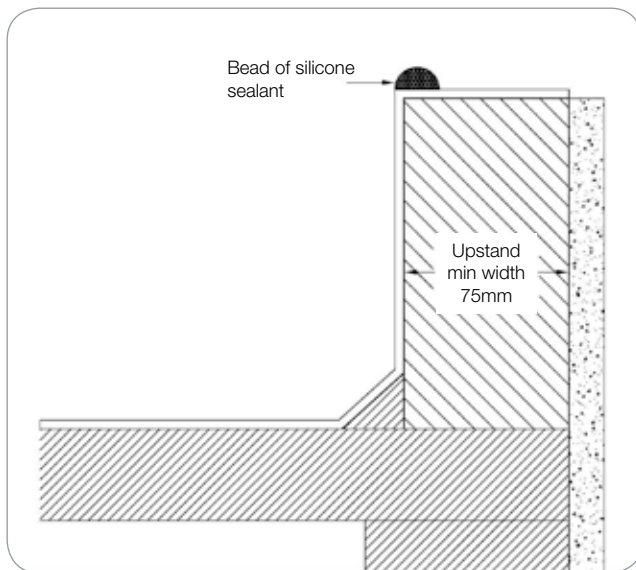

Figure 2



2. Installation



- 1** Ensure the kerb is clean and free from debris, then run a silicone bead around the external edge as shown above.

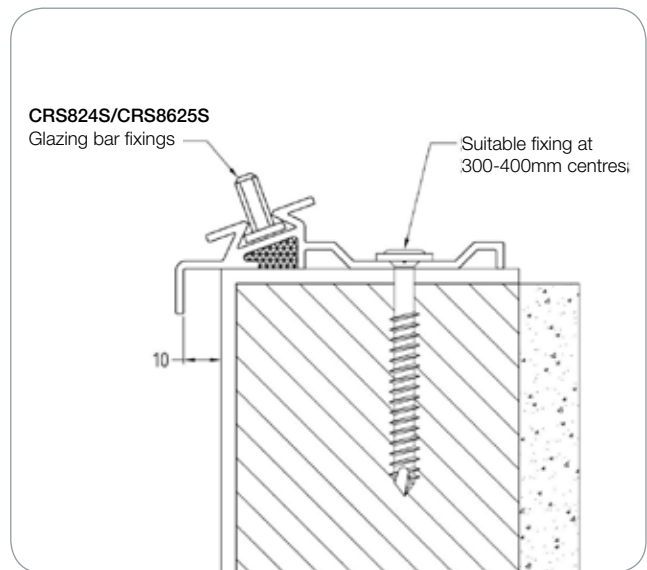

- 2** Ensure the correct amount of glazing bar fixing studs are slid into the ring beam before any fixing commences. Position the ring beams so an equal over hang is achieved around perimeter and fix using suitable 5-6mm fixing at 300-400mm centres starting and ending 100mm away from internal corner of the ring beam.



- 3** Run a bead of silicone sealant along the mitred edge of the ring beam to seal the corner joint, when the next ring beam is offered up.



- 4** Fix the adjacent ring beam ensuring the joint is tight. Remove any excess sealant and secure corner using a steel corner cleat with 4-off 4.8x25 LG screws (supplied).

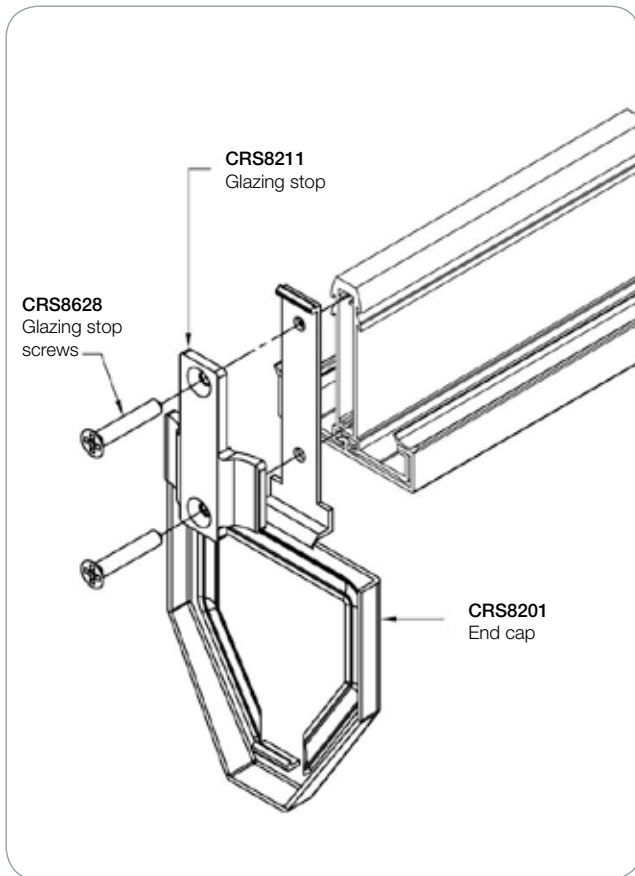

5 If access to the bar ends is limited, it is advisable to fit the glazing stops and end caps as shown (left) before fixing rafters to the ring beam. You can then proceed to loosely secure the side rafters to the ring beam using the threaded studs located down the ring beam.

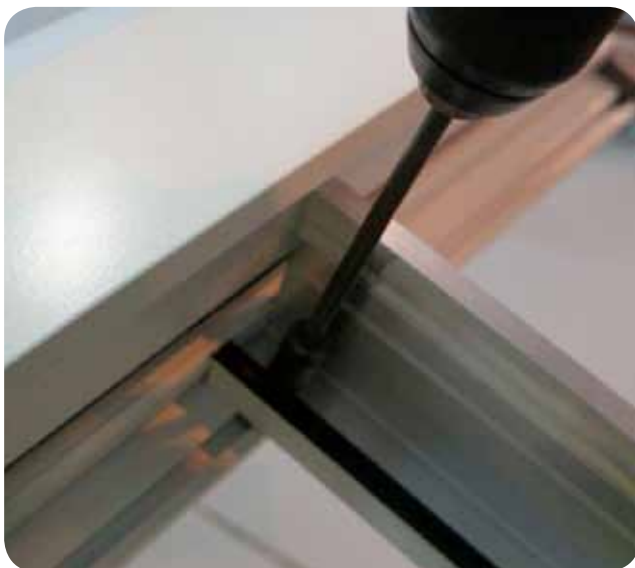

6 Supporting the ridge, the rafter bars can be secured to the ridge using the threaded studs. Once opposing rafters have been secured the ridge should be self supporting.



7 Using 2 x CRS8624S single studs, secure each hip to the spider casting. The body of the stud should locate between the retaining ribs on the lower casting face to stop the stud from spinning.



8 Locate the hips onto the external ring beam studs and loosely secure using fixing nuts.

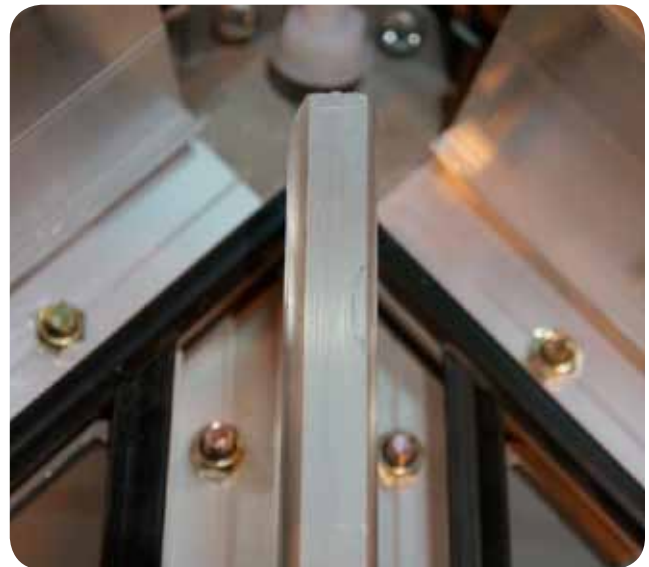

9 Fasten the central rafters to the spider using 1 x CRS8625S double stud and nuts. If jack rafters are present refer to additional information at end of this guide.

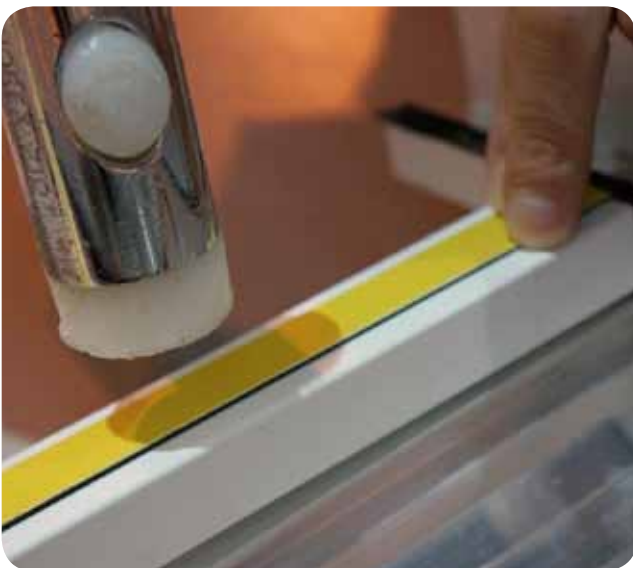

10 If not already fitted, clip in the eaves beam seals between the rafters and hips using a nylon mallet. Check the rafters are all square to the ring beam and ridge, and then tighten all roof fixing nuts.



11 Locate the nylon bar through the spider and lock off using nuts and washers either side of the spider. The nylon bar should sit 5mm below the crest of the ridge profile.



12 Position the spider bottom cap and fix using the decorative boss onto nylon threaded bar. Note the nylon bar may require trimming down in length.

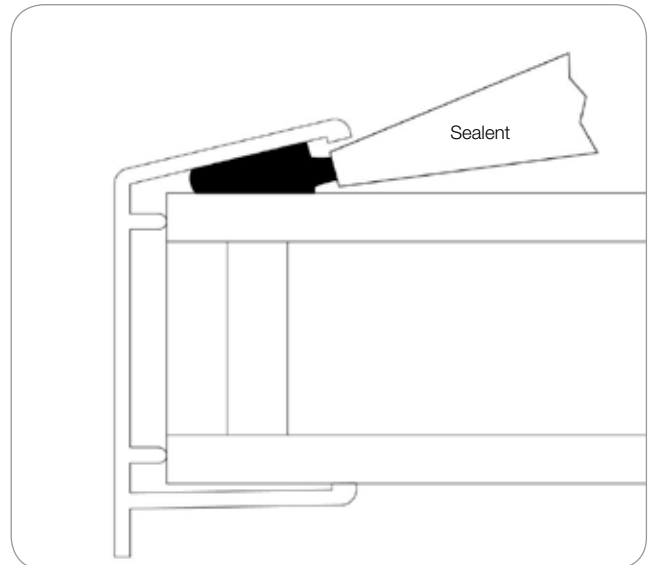

13 Fit the glazing end closures to the glass and run a bead of sealant between the profile and top pane of glass as shown above. **ONLY** use a suitable sealant with self cleaning glass. Soudal SMX 506 is recommended.

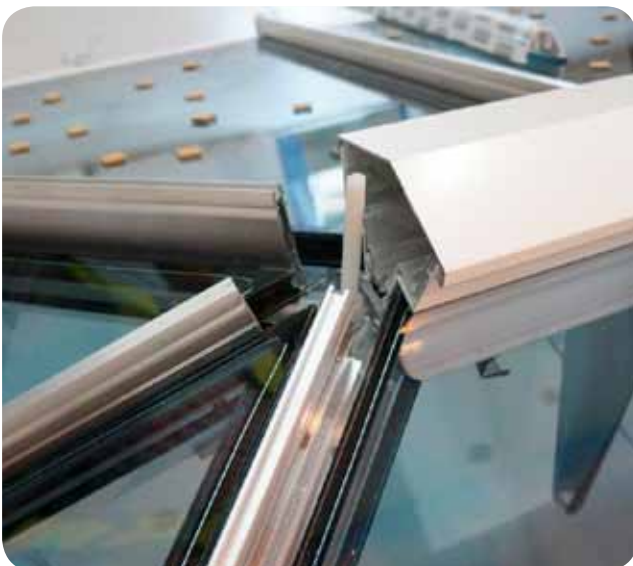

14 If not already fitted, fit the glazing bar end caps and glazing stops. Then peel back two inches of eaves beam seal tape film and fold to the outside. Insert glazing unit ensuring equal coverage and ensuring the glass is resting onto the glazing stops.



15 Fit the foam bung and clamp plate and tighten M10 nut until the foam is firmly pressed down onto glazing.

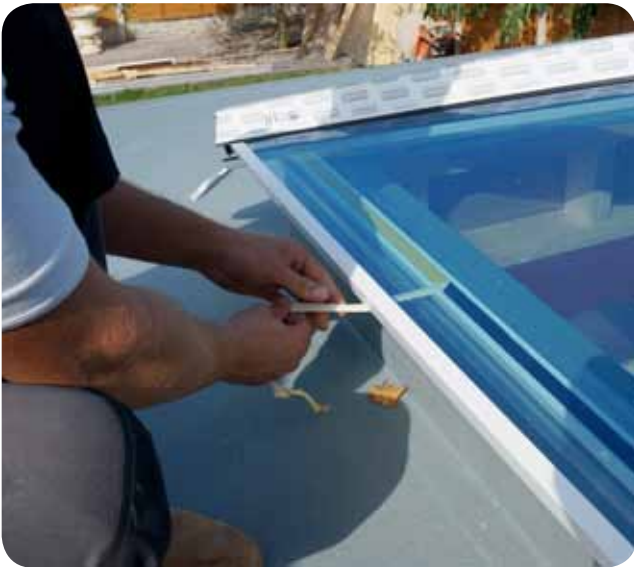

16 Fit the rafter and hip top caps using a nylon mallet, then ensuring the glass is positioned correctly, peel the remaining eaves beam seal tape film away and press glazing down to ensure contact with eaves tape.



17 Seal around perimeter of the foam bung where it intersects the ridge glazing seal, glass and glazing bar top caps.



18 Seal around rafter top caps to ridge glazing trim.



19 Seal the rafter top cap to hip top cap from the gasket intersection to foam bung.



20 Using a suitable high grab adhesive sealant, run a small bead on the perimeter edges and a larger bead further inboard as shown. Recommended sealant is Soudal Fix All Super Clear.

NOTE: Do not run the sealant to the bottom edge around the hip/rafter area to ensure the sealant does not touch the glass. Always ensure hands are cleaned as to not contaminate self cleaning glass.



21 Splay the top cap and lower onto the ridge whilst checking the capping is positioned correctly over the rafter and hip top caps. The capping returns should clip under the ridge profile when positioned correctly.



22 Ensure the capping is seated down correctly and remove any excess sealant from all edges.

3. Additional Information

Jack rafter installation

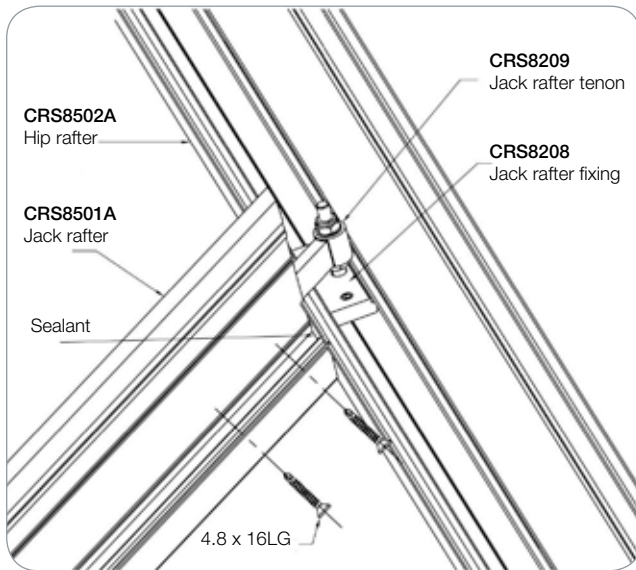

1 Locate the jack rafter tenon onto the jack rafter fixing bolt and adjust the lower nut to align gaskets then tighten the top nut. Seal the jack rafter internally to the hip.

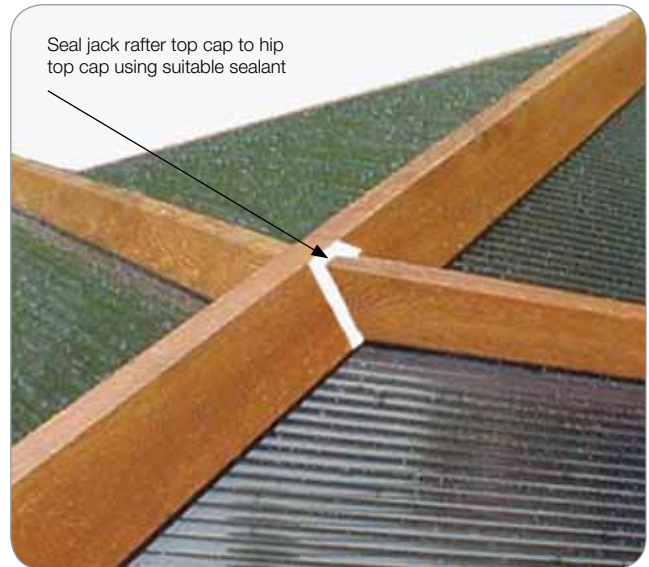

2 Seal jack top capping joints. ONLY use suitable sealant with self cleaning glass.

Eurocell - the UK's leading PVC-U specialists



- ▶ Unique colour-match promise - we are the only brand to guarantee an exact colour match across our full range of window, door and roofline products
- ▶ Products specially designed for ease of fabrication and fitting - improving your productivity
- ▶ Widest product range of any PVC-U systems supplier in the UK
- ▶ 10-year profiles guarantee assures you of high quality
- ▶ ISO14001 environmental management system accreditation



The UK's leading PVC-U specialists

As the UK's market-leading manufacturer and distributor of quality PVC-U profiles, Eurocell offers precision-manufactured products and a complete one-stop-shop range for new-build and replacement projects.

Sustainable standard

To support our ongoing commitment to sustainability, Eurocell has achieved the ISO14001 environmental quality standard.

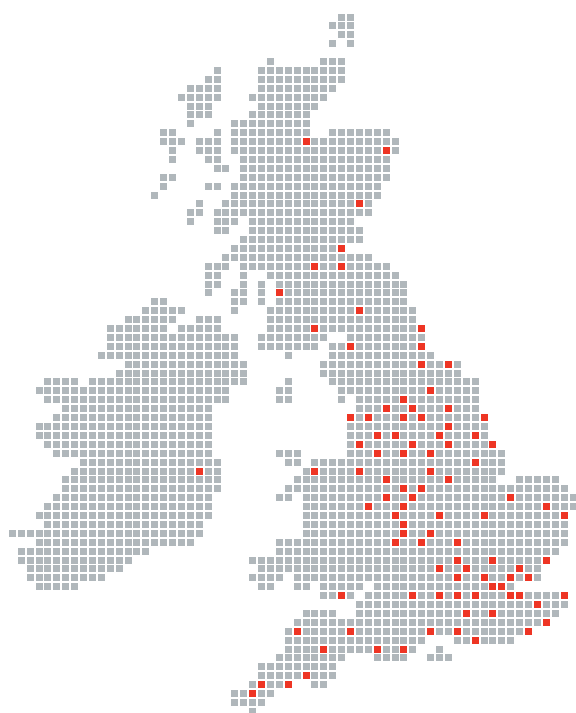



All together better



Eurocell plc, Fairbrook House, Clover Nook Road, Alfreton, Derbyshire DE55 4RF

Product specification is subject to change without notification. Please also note that colours shown are illustrative only, as the printing process does not allow 100% accurate colours to be reproduced.