

OWNER'S MANUAL & INSTALLATION GUIDE

Heaton Estate
Bradford Road
Brighouse
West Yorkshire
HD6 4BW

Tel 0844 5610 623
Fax 0844 5610 624
sales@quickslide.co.uk
www.quickslide.co.uk

Important notes for the client prior to use.

Please note a video guide is available on our website at quickslide.co.uk/installation-services/installation-guides

WARNING

Read these instructions prior to installation and operation of the folding-sliding doors. Please ensure that while opening and closing the folding sliding doors you do not get your fingers trapped between the panels.

Please ensure you inspect the product prior to installation. It's important you inform us of any issues and provide photographic proof prior to removing the protection tape.

**REMOVE KEYS AFTER UNLOCKING THE DOORS
AND BEFORE FOLDING THE DOORS!**

BASIC OPERATION OF FOLDING- SLIDING DOOR WITH TRAFFIC DOOR

TO OPEN

1. Unlock the traffic door and open it 180 degrees. This door will then close on to the next door via a magnetic panel catch (supplied in the parts box).
2. Unlock the remaining intermediate door panels using the intermediate handle (you do this by turning it nearly 180 degrees from pointing down (locked) to pointing up (unlocked)).
3. Fold panels pair-by-pair sliding all of the panels carefully over to the side so they are all stacked together.

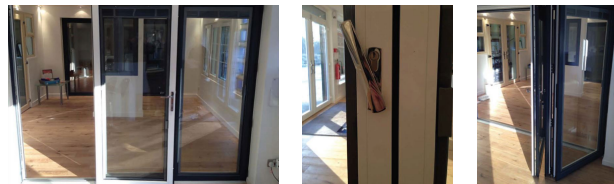

1

2

3

TO CLOSE

- As described previously but in reverse order;
1. Slide the pairs of intermediate door panels one-by-one back in to the frame so they are shut.
 2. Lock each of these pairs off as you close them in to the frame.
 3. The traffic door should remain open and be the last door you close.
 4. Pull the traffic door closed and lift the handle upwards to engage the locking system in to the frame so they are all stacked together.

BASIC OPERATION OF FOLDING- SLIDING DOOR WITHOUT TRAFFIC DOOR

TO OPEN

1. Unlock all internal handles.
2. Slide the panels pair-by-pair slowly to the side so that they are all stacked together.

TO CLOSE

1. Pull the handle between the panels closed so that you are working from the final set of opening panels to the first set of opening panels. Once these panels are pulled back tight against the frame, turn the handle to secure.
2. Pull the second pair of panels closed and lock in to the frame and turn the handle to secure.

OWNER'S MANUAL & INSTALLATION GUIDE

Heaton Estate
Bradford Road
Brighouse
West Yorkshire
HD6 4BW

Tel 0844 5610 623
Fax 0844 5610 624
info@quickslide.co.uk
www.quickslide.co.uk

ON SITE ASSEMBLY

ANY DOOR SUPPLIED WITH 4 PANELS OR MORE WILL BE SUPPLIED WITH THE FRAME COMPLETE BUT THE DOOR PANELS SEPERATE

ANY DOOR SUPPLIED WITH 3 PANELS OR LESS WILL BE SUPPLIED WITH THE DOOR PANELS ALREADY FITTED TO THE OUTER FRAME

GLASS UNITS WILL ALWAYS BY SUPPLIED LOOSE

INSTALLATIONS INSTRUCTIONS

IMPORTANT - Please ensure that the instructions are fully read and understood prior to beginning the installation of the door. If the installation guide is not followed properly, this could result in the unit not operating correctly.

CAUTION - Regulations governing the use of glazed windows, doors, storefronts and/or partitions vary widely. It is the responsibility of the building owner, architect, contractor or installer to insure that products selected confirm to all applicable codes and regulations.

Quickslide Ltd. can assume no obligation or responsibility whatsoever for failure of the building owner, architect, contractor or installer to comply with all applicable laws and ordinances and safety and building codes with the exception of CE Marking.

PREPARATION OF THE OPENING

Make the aperture 15mm wider and 15mm higher than the outside frame size of the unit ordered.

Please note that the outside frame height of the required unit is measured from the underside of the sill and NOT FROM THE FINISHED FLOOR LEVEL.

IMPORTANT - Due to the large opening sizes, weight and movement of the panels, any application should take into consideration the following:

1. The rough opening should be level, plumb and square at all points. There should be no unevenness or bowing. Make sure that the header is not twisted. There should be no bumps on the floor. The sides should be in the same vertical plane and not offset from each other. A telescopic rule and other similar precise measuring equipment should be used to make these determinations.
2. The structural integrity of the header is critical for the proper operation. Deflection of the header should be limited to L/720th under full live and dead loads with a maximum deflection limit of 9mm.
3. A qualified engineer or architect should be used to determine the proper construction details and header to be used in your particular application.

TO AVOID FUTURE PROBLEMS, DO NOT INSTALL THE UNIT UNTIL THE ROUGH OPENING HAS BEEN CORRECTLY PREPARED.

HANDLING OF COMPONENTS

1. Upon receipt of the products, please carry out a thorough inspection to ensure that all items have been delivered in good suitable condition.
2. Store the products in a secure, clean and dry environment and protect against defacement or damage.
3. Mark sure that the parts box supplied is not mislaid.

OWNER'S MANUAL & INSTALLATION GUIDE

Heaton Estate
Bradford Road
Brighouse
West Yorkshire
HD6 4BW

Tel 0844 5610 623
Fax 0844 5610 624
info@quickslide.co.uk
www.quickslide.co.uk

PARTS & ANCILLARIES BOX CHECKLIST

NAME OF PART	QUANTITY
External hinge plates (black)	1 x per hinge (excluding wheels and guides)
Keys	At least 3 x keys supplied
First fix screws	2 x per hinge (including wheels and guide)
Final fixing screws (25mm)	8 x per glass unit
Toe and Heel glazing packers	1 x traffic door (supplied with own instructions and fixings)
Magnetic panel catch	1 x per traffic door
Lifting block and screw (traffic door only)	1 x per box
Toe and Heel diagram	1 x per box
Sill and caps (if applicable)	1 x pair per sill

1 x 3mm Allen Key required (not supplied)

FOR ALL SYSTEMS USE APPROPRIATE SCREW OR OTHER EQUIVALENT ANCHORAGE DEVICES DEPENDING ON THE HEADER MATERIAL AND CONSTRUCTION. ANCHORAGE DEVICES SHOULD PENETRATE OR HOLD SUFFICIENTLY TO THE HEADER TO WITHSTAND NECESSARY STRUCTURAL LOADING.

INSTALLING THE OUTER FRAME (REQUIRES MIN. 2 PEOPLE)

1. Remove all door panels from outer frame making a note of each one's location in the frame. 2 people should lift the outer frame in to the aperture and on to the sill.
2. If there is no sill applicable to your order then please refer to the instructions below;
 - a. Create a silicone bed on the masonry for the outer frame to sit on.
 - b. Temporarily secure the frame to the rough opening with clamps.
 - c. Make sure that the frame threshold is packed underneath to make it level and plumb (packers not supplied).
3. Pre-drill all fixing points first then fix through the thermal break of the outer frame in to the masonry using suitable frame fixings (not supplied).
4. Fix through the thermal break of the outer frame in to the sill at 100mm from each end and 600mm between.
5. Before fixing the sides and head, the outer frame should again be packed suitably to ensure it is square and plumb.
6. Fixing points should be set 100mm from each corner of the outer frame and then every 600mm between.
7. Once the outer frame is fixed in place, it should be level, square and plumb, this should be checked at every 600mm in both width and height using a suitable measuring device.

INSTALLING THE SILL

1. If the bi-fold has a projecting sill (150, 190 or 225mm) fill the ends with silicone before the end caps go on to prevent a potential leak.
2. Fit the sill end caps to the sill using a suitable silicone (not supplied).
3. Make a silicone bed on the masonry, sit the sill in to the aperture and pack underneath to make it level, then fix through the thermal break of the sill into the masonry. (Fig 1)
4. If the thermal break of the sill sits over a cavity, then you are able to put a fixing through any point of the sill providing that it is covered by the outer frame. We would suggest that you use the thermal break as the first choice fixing point where possible.
5. You must ensure that you apply additional silicone sealant to the ends of the sill where it meets the masonry as this will always be the most susceptible point for water ingress.
6. When you are ready to sit the outer frame on to the installed sill, you should first run a line of silicone across the internal up-stand of the sill. (Fig 2)

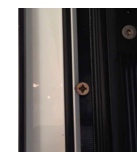

1

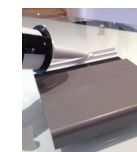

2

QUICK SLIDE
WINDOWS & DOORS

OWNER'S MANUAL & INSTALLATION GUIDE

Heaton Estate
Bradford Road
Brighouse
West Yorkshire
HD6 4BW

Tel 0844 5610 623
Fax 0844 5610 624
info@quickslide.co.uk
www.quickslide.co.uk

NEW ADJUSTABLE JAMB

The purpose of the adjustable jamb is maximum adjustability of roughly +/- 4mm either side during install. Additionally, the jamb is easily adjustable at a later date with an allen key.

The adjustable jamb will be pre-fixed and positioned between the first sash and outer frame as highlighted in the image below. The jamb will sit onto the adjustable jamb fixings using the pre-drilled holes. Do not attempt to remove the adjustable jamb.

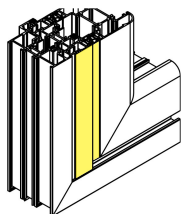

PLEASE NOTE: Configurations of 4 panels or more will come with an adjustable jamb.

INSTALLING THE DOOR PANELS

1. All loose door panels will carry a numerical label which stipulates the order in which they should be fitted in to the outer frame.
2. Door '1' will have hinges on one side only which will then connect to the outer frame using the 'first fix' screws and external hinge plates.
3. The external hinge plates are first to be located on top of the hinge, as shown. (Fig. 1)
4. This should be repeated on the remaining hinges on door 1.
5. Repeat the above steps fixing door 2 to door 1 etc...

Hinge plate, fitted on top of the main body of the hinge



1

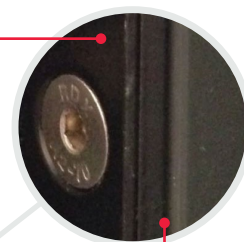

Main body of the hinge

INSTALLING A DOOR PANEL

1. The sliding post will always be hinges to a door panel so this item does not require any additional construction.
2. This type of door panel is hinged the same way as a standard panel but should be fitted in to the outer frame on an angle so that the guides are able to clear the outer frame and sit in to the rebated channels at the top and bottom of the outer frame.

INSTALLING A DOOR PANEL WITH WHEELS AND GUIDES

1. The wheels and guides will always be attached to the relevant door panel and are part of the top and bottom hinge assembly.
2. These require hinges unlike the standard ones DO NOT require hinge plates to be fitted.
3. This door panel should be fitted in to the outer frame on an angle so that the guides and wheels attached to the sliding post are able to clear the outer frame and sit in to the rebated channels at the top and bottom of the outer frame.

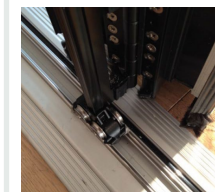

Bottom Roller Hinge
2



Top Guide Hinge
3

OWNER'S MANUAL & INSTALLATION GUIDE

Heaton Estate
Bradford Road
Brighouse
West Yorkshire
HD6 4BW

Tel 0844 5610 623
Fax 0844 5610 624
info@quickslide.co.uk
www.quickslide.co.uk

FINAL FIXING SCREWS

1. Once all of the door panels have been fitted, you should ensure that all of the heads of the door panels 'line-through' with each other. (Fig 1)
2. Assuming the panels do line-through then you can fit the 'final fixing screws' to the centre hole of ALL hinges including rollers and guides. (Fig 2)

The final fixing screws need to go in prior to glazing due to the weight of the glass.

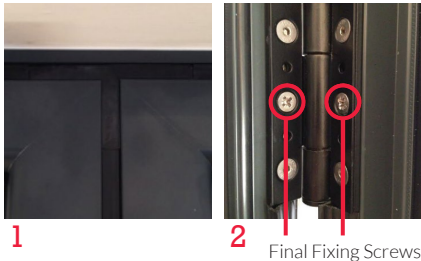

GLAZING

ALL GLAZING SHOULD BE CARRIED OUT BY A COMPETENT GLAZIER. GLAZING PACKERS AS WELL AS A TOE AND HEEL GUIDE HAVE BEEN INCLUDED.

1. Remove the pre-glazed beading (4 per sash) keeping track of which bead goes where.
2. Follow the toe and heel glazing guide for details on packer locations.
3. Fit the bottom packers only prior to the glass units being installed.
4. Lift the glass units into the door panel (2 people required).
5. Fit remaining toe and heel wedge packers.
6. Tap in the glazing beads in the relevant locations. Glazing beads come with integrated gaskets.



7. Repeat on all remaining door panels.

FINAL CHECKS

1. After installation of the glass units, you should check the operation of the door to ensure that it is smooth with no catching door panels. If you find that a panel is catching you will need to adjust the toe and heel of the relevant glass unit.

2. You should have an 11mm gap between the edge of the door panel and the edge of the outer frame (gasket line). This is applicable to all 4 sides of the outer frame. (Fig 1)

3. You should ensure that all locking mechanisms operate correctly (traffic doors and intermediate doors).

4. There should be no debris or residue in the bottom channel of the outer frame where the roller-bearing wheels are located.

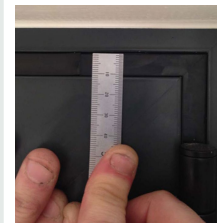

ADJUST HINGES

1. The hinges can be adjusted up and down using an Allen key. This is done via a grub screw located on the internal of the hinge. In order for the adjustment to be effective, the final fixing screws will need to be removed and the first fix screws loosened.

2. Toe and heel glass units for adjustment on the intermediate doors.



OWNER'S MANUAL & INSTALLATION GUIDE

Heaton Estate
Bradford Road
Brighouse
West Yorkshire
HD6 4BW

Tel 0844 5610 623
Fax 0844 5610 624
info@quickslide.co.uk
www.quickslide.co.uk

TOE & HEEL GLAZING GUIDE

Bi-fold door sashes are heavy, and although the dead weight is supported on the hinge side there is nothing on the lock side to support the weight. Toe and heeling of each sash is therefore essential to prevent the doors dropping and catching. This is especially a must for sashes wider than 1000mm. For sashes under 1000mm in width, standard 2-4mm wedge packers will be supplied.

We recommend following the steps below that explains how to use the device to reinforce the door, which essentially enables the glass to support its own weight. Please note not all doors come with a toe and heeler device and some doors may require conventional toe and heeling.

A step-by-step installation video is available on our website at www.quickslide.co.uk/how-to-install-a-bi-folding-door/

TOE AND HEELER DEVICE (ACDV295)

The Toe and Heeler device comes in 4 separate parts as shown to the right.

- a) Adjustment Screw
- b) Base Plate
- c) Steel Plate
- d) Corner Packer

The Base Plate and Adjustment Screw are pre fitted to the sash in the factory.

The Steel Plate and Corner Packer will come in the stores package and must be used in place of standard packers in the corners where the device is fitted.

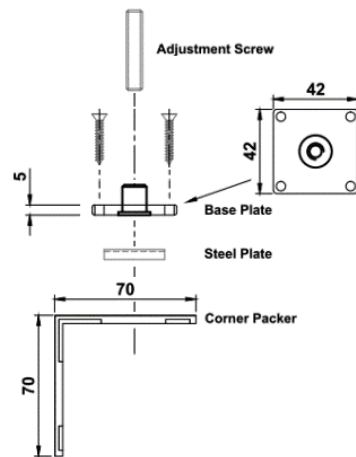

WHERE TO FIT THE DEVICE(S)

To stop a door sash dropping it needs to be braced diagonally corner to corner by the Toe and Heeler devices between the glass and the frame. On the hinge side of the sash the devices go at the bottom corner, whilst on the lock side they go at the top (opposite corner).

Below is an example of where to fit the Toe and Heeler devices, you should use the same principle when glazing other configurations.

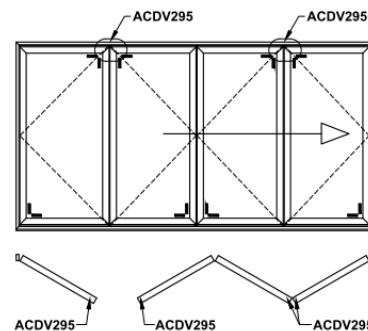

FITTING WITH A 28MM GLASS UNIT

The Toe and Heeler device will require a notch to be cut out when fitting 28mm units to allow the bead to sit in place, as shown below.

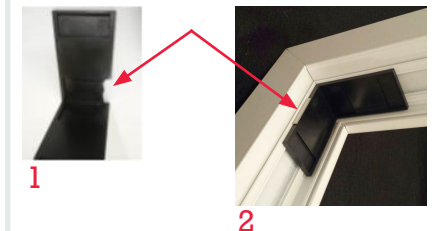

Please note: Failure to install all of the parts will invalidate the guarantee and could potentially shatter the glass unit.

OWNER'S MANUAL & INSTALLATION GUIDE

Heaton Estate
Bradford Road
Brighouse
West Yorkshire
HD6 4BW

Tel 0844 5610 623
Fax 0844 5610 624
info@quickslide.co.uk
www.quickslide.co.uk

FRAME ASSEMBLY FROM KIT FORM

If you've requested the frame to be supplied in kit form, you are encouraged to carefully read the below instructions to correctly assemble the outer frame.

Step 1: Parts Box

If your bi-folding doors have been supplied in kit form, you will receive a parts box which include the following:

4 x silver tensions blocks per corner (total of 16 per panel)

2 x final fixing screw per hinge

8 x packers per panels

4 x 50mm screws if you've opted for a low threshold

Lifting block(s) if specified

1 x 3mm Allen Key required (not supplied)

Step 2: Remove Packaging

Remove the outer frame from its packaging and lay out the frame on a flat surface working area. The working area should be twice the height and width of the door.

The bottom of the frame will feature a drainage and steel track.

Step 3: Assemble Outer Frame

2 of the frame pieces will have 2 metal cleats (see illustration 1). Before assembling the pieces together, you will need to use silicone around the edges to weatherseal the frame. The pieces should then be inserted into the channels. Once inserted place the silver tension blocks in the pre-punched holes.



1

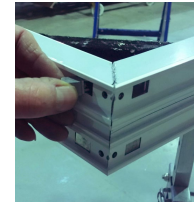

2

Once the silver tension blocks have been inserted use the 2.5mm Allen key to tighten grub screws making sure surfaces are level.



3

Step 4: Gasket

The outer frame will come with a flipper gasket attached. This will need to be pushed in to the grooves all the way round the frame.



4